

# **STRYKER** **T-TOPS**

## **SG900** | **INSTALLATION GUIDE & OWNERS MANUAL**

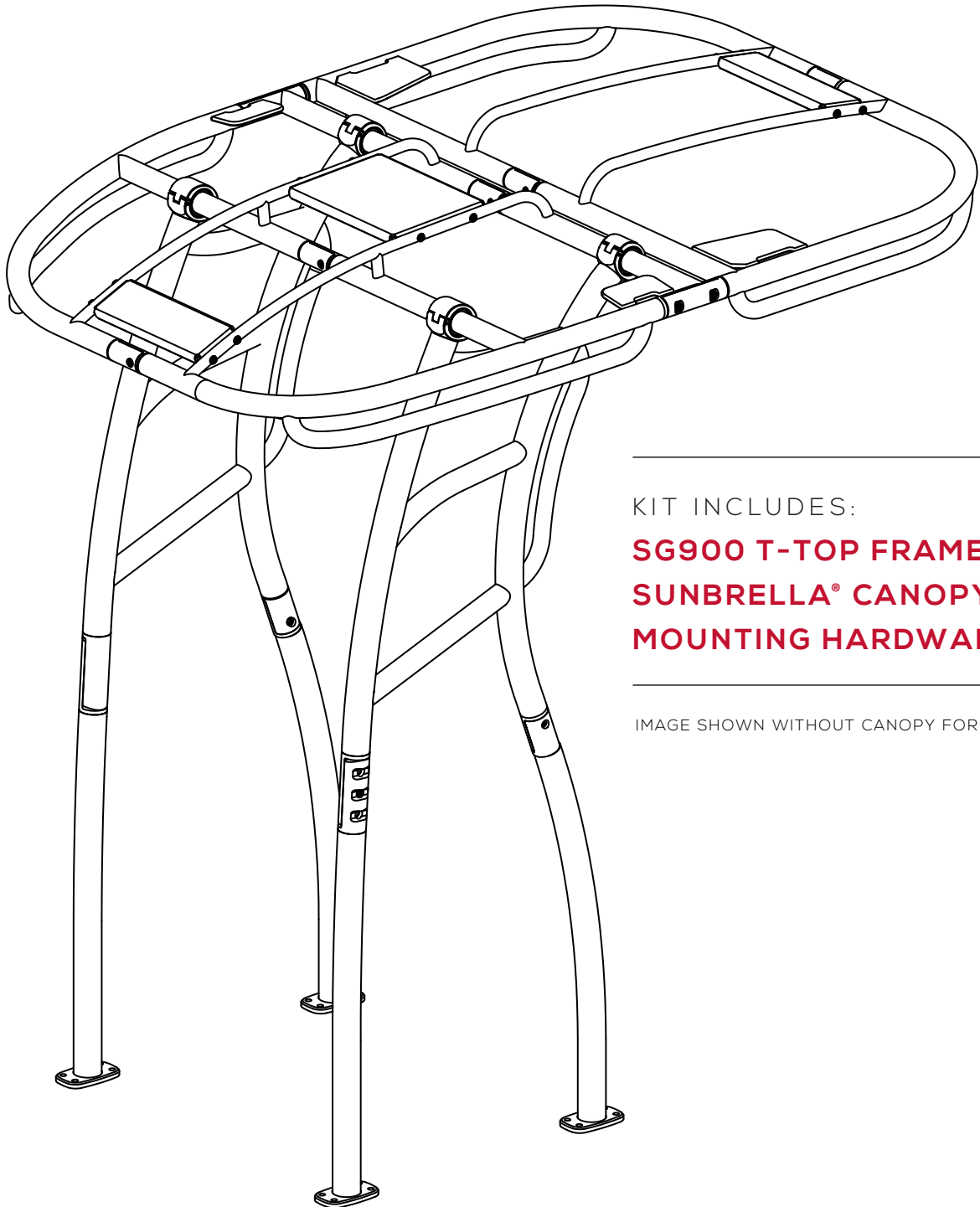

---

KIT INCLUDES:

**SG900 T-TOP FRAME**  
**SUNBRELLA® CANOPY**  
**MOUNTING HARDWARE**

---

IMAGE SHOWN WITHOUT CANOPY FOR CLARITY

# Congratulations!

## ON YOUR STRYKER T-TOP PURCHASE

You have selected a quality aftermarket t-top to upgrade your center console boat. Properly installed and maintained, it will provide many years of valuable protection from the sun and elements. Fully customizable with many Stryker accessories, you will greatly increase the functionality and resale value of your boat. We thank you for your purchase and promise to provide the very best in customer service for the lifetime of ownership. After you complete your installation, remember to send us photos for our customer gallery and leave your product reviews at [www.strykertops.com](http://www.strykertops.com).

### **BEFORE YOU GET STARTED**

Read the entire manual before beginning the installation. Do an inventory check. Lay all the parts out on a soft cloth to avoid scratching the finish. Compare what you received with the parts list on the following page. If you are missing any parts, contact us before starting the installation. Make all measurements before you begin to ensure the t-top is installed square and in the correct position. Be sure to have all the items in our required tools section ready before you begin. To avoid scratching your deck, use blue painter's masking tape to cover the area where the feet will be mounted. Mark drilling spots on the tape with a marker- if you mess up a measurement, you can replace the tape and start over. When drilling through fiberglass, always run your drill in reverse to lessen the chance of spider cracking. To avoid drilling through tanks or cables under the deck, refer to your boat's owner manual or contact the manufacturer. When drilling, limit downward pressure- don't let the drill bit punch through more than one inch. This is not a one person job so make sure you have someone to help or check our site for installers in your area.

We proudly offer support for the lifetime of original ownership. If you ever need help or have installation questions, call our support team at (949) 407-5000 or email [support@strykertops.com](mailto:support@strykertops.com) Monday through Friday 9am to 5pm Pacific Standard Time.

### **LIST OF RECOMMENDED TOOLS & SUPPLIES**

Power Drill	Allen Wrench Set	Anti-Seize Lubricant
Drill Bits	Measuring Tape	3M 5200 Marine Adhesive
Phillips Head Driver Bit	Marker Pen	Hack Saw
45° Chamfer Bit	Painter's Masking Tape	Miter Box
Wrenches (socket or adjustable)	Thread Lock Glue	A Buddy to Help Out

## DIMENSIONS

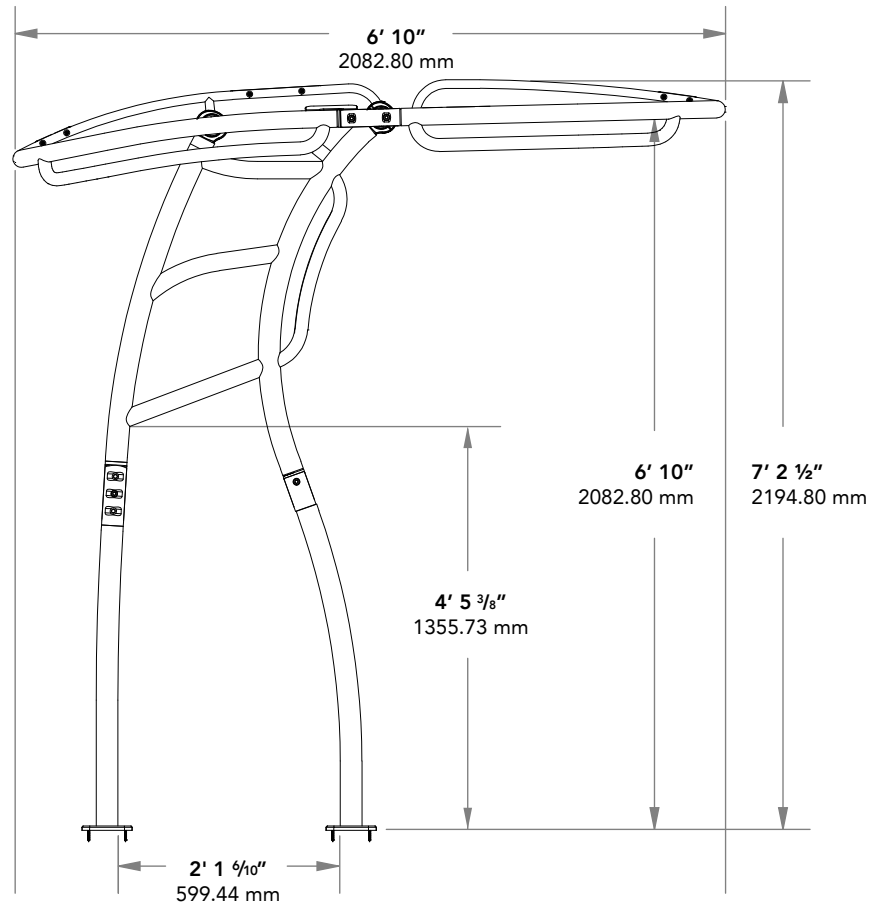
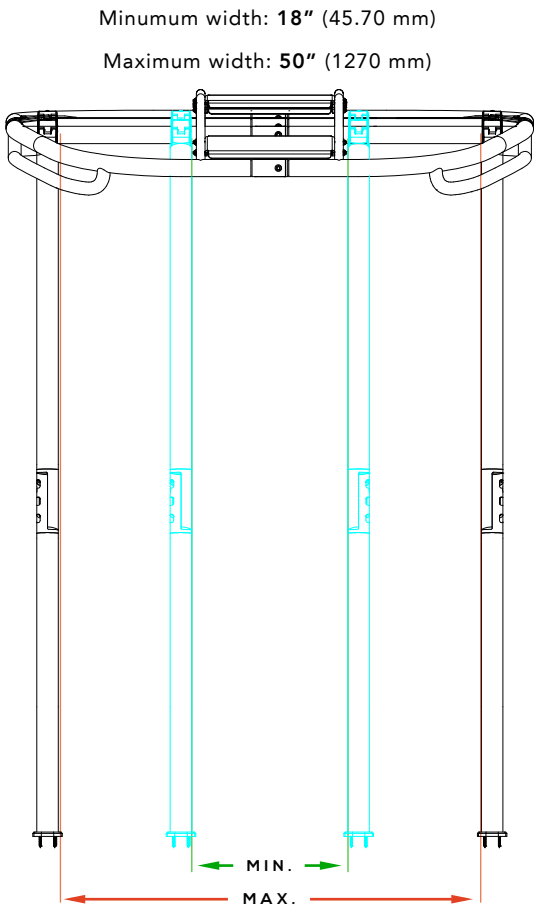

### ADJUSTABLE WIDTH

The leg sections can be moved in or out to fit most center consoles.

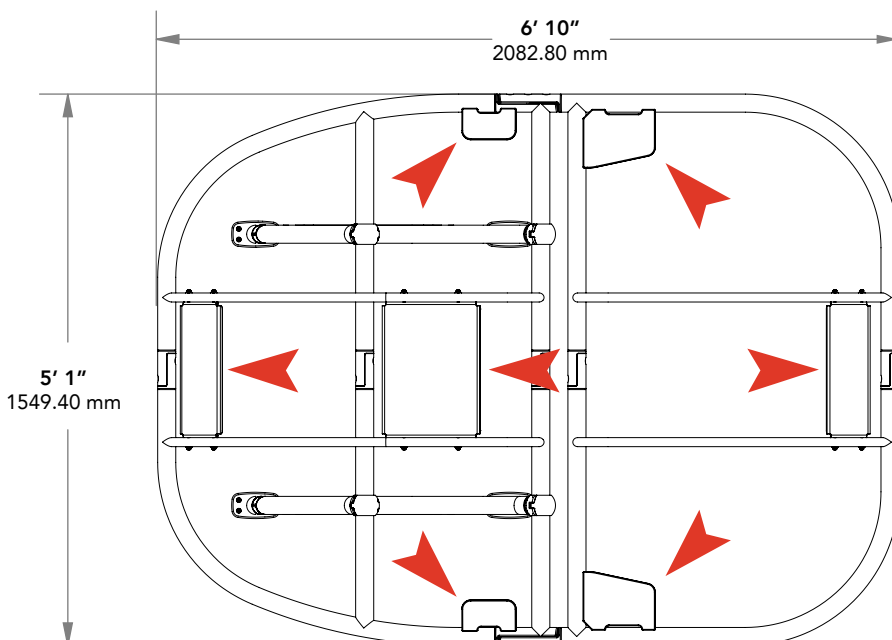

### FEET

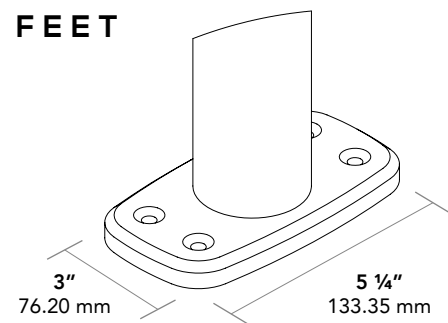

### MOUNTING PLATES

The SG900 comes with 7 accessory mounting plates perfect for outriggers, flood lights, antennas, radar, etc. Four are welded on the frame and three are mounted with the included hardware.

## PARTS LIST

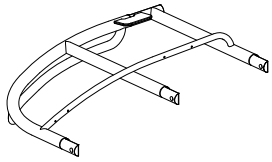

Front Starboard Top Section X1

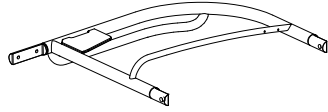

Rear Starboard Top Section X1

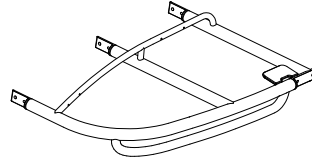

Front Port Top Section X1

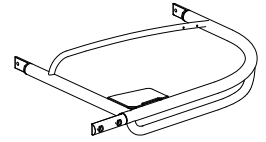

Rear Port Top Section X1

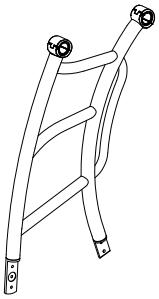

Starboard Upper Leg Section X1

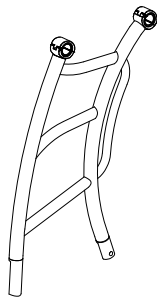

Port Upper Leg Section X1

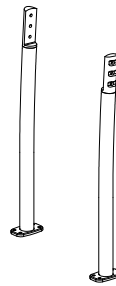

Front Leg Sections X2

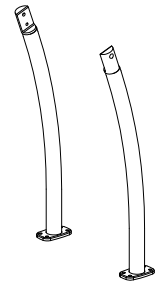

Rear Leg Sections X2

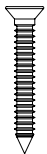

Deck Screws X16

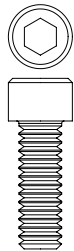

Leg & Top Section Bolts X24

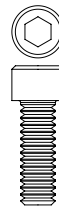

Clamp Bolts X8

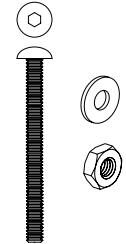

Mounting Plate Hardware Set X12

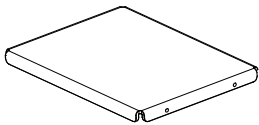

Large Mounting Plate X1

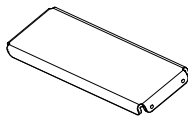

Small Mounting Plate X2



Nylon Washer X2

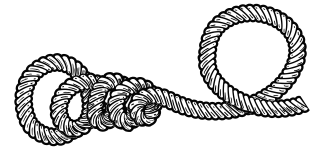

Canvas Cord X1

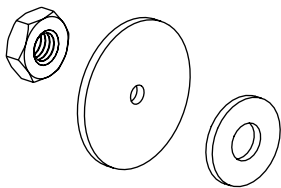

Standoff Hardware Set

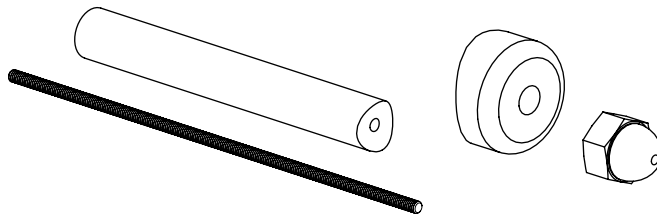

X4

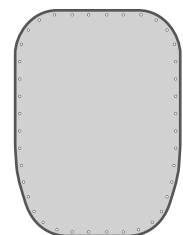

Sunbrella® Canvas Canopy X1

**CAUTION!**

Check for wires, water/fuel tanks & lines before you drill into your deck.

If unsure, contact your boat's manufacturer.

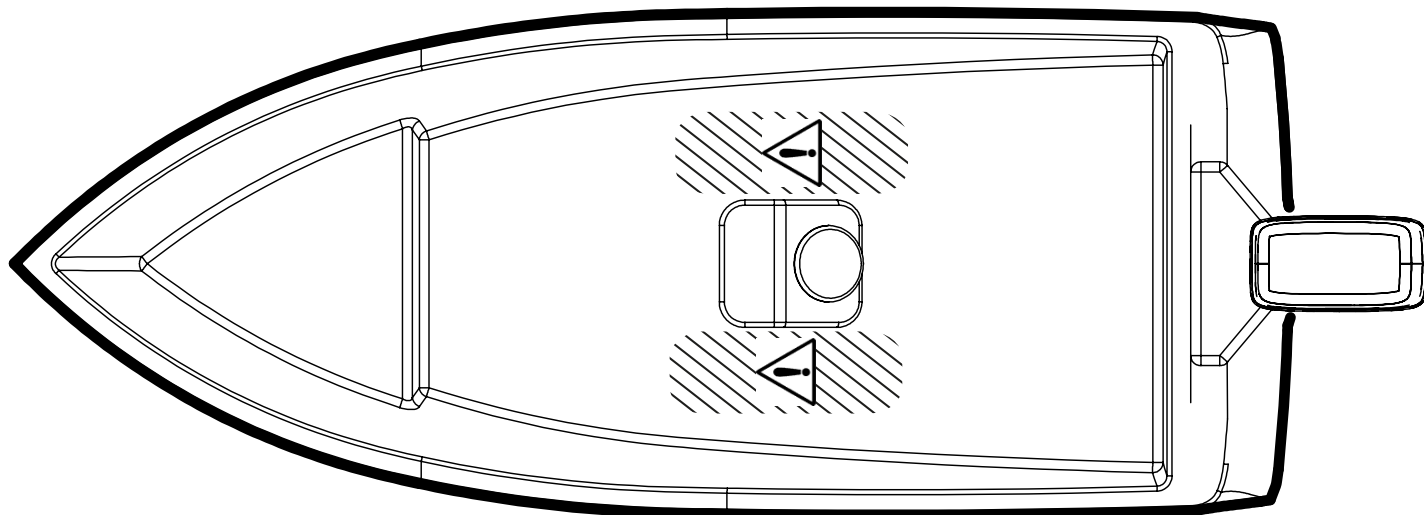

**STEP 1**

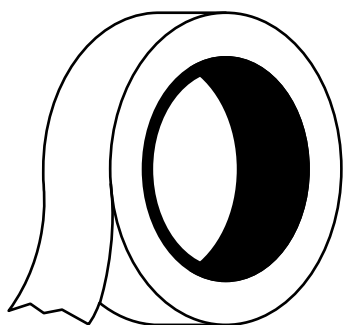

Lay overlapping strips of blue painter's tape on both sides of the deck next to the center console unit. This will protect your deck from scratches and provide a surface for marking drill holes.

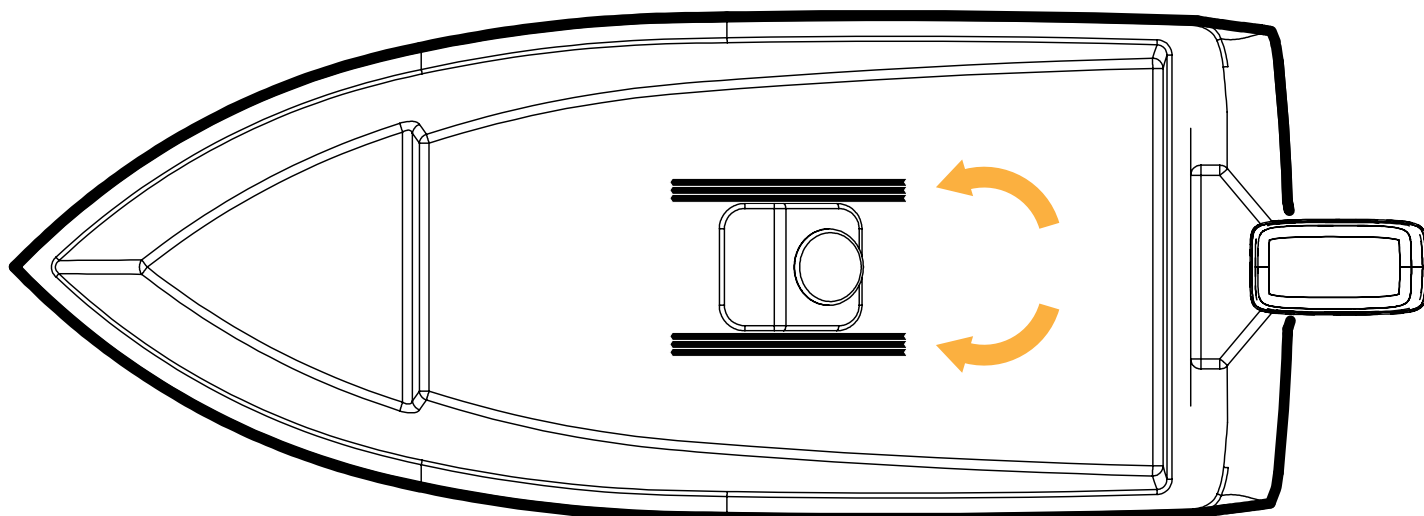

## STEP 2 ASSEMBLE THE LEG SECTIONS

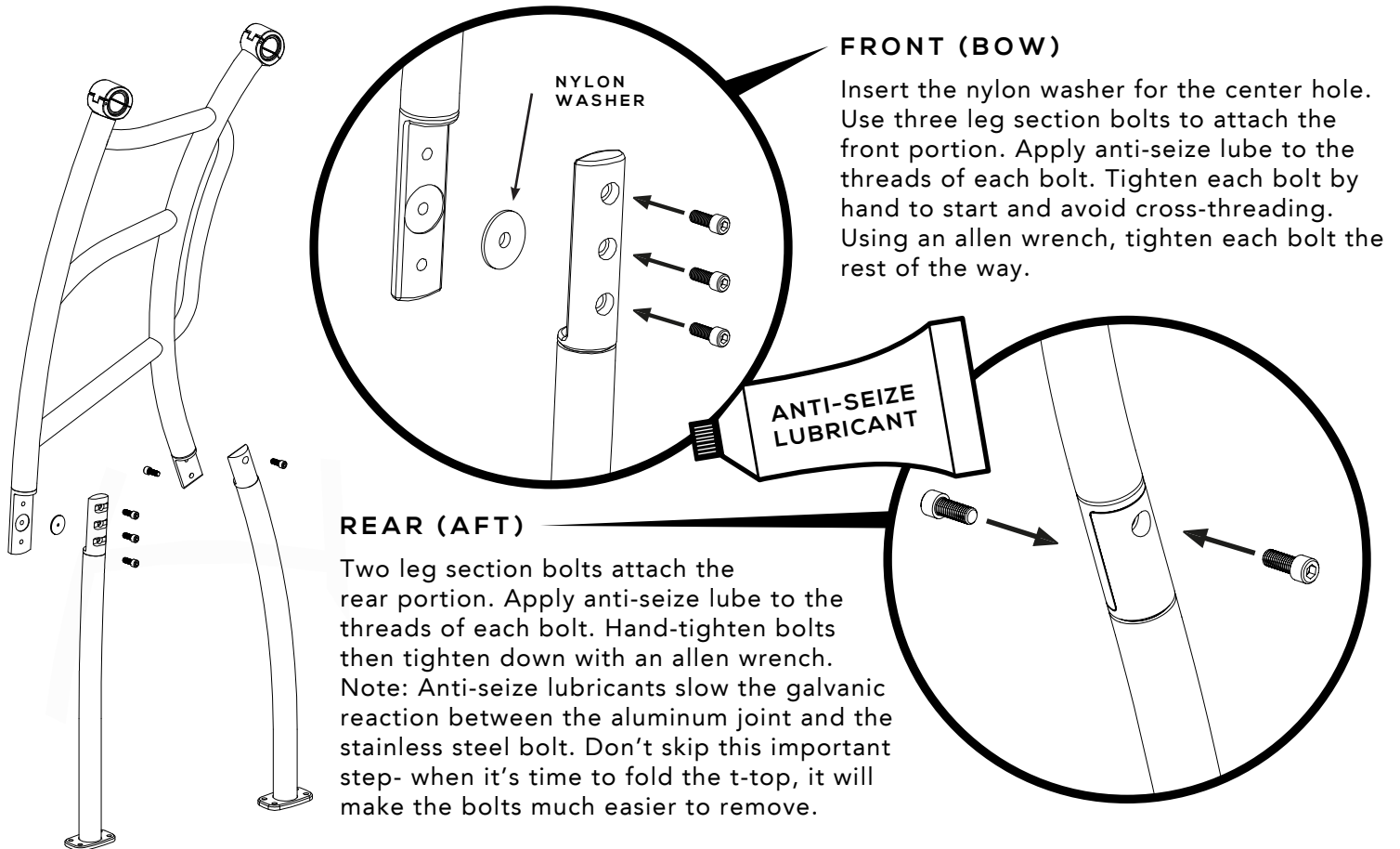

## STEP 3 POSITIONING OF SIDE SECTIONS

At this stage, it is very important to know where you will be installing the stand-offs that connect both the t-top's leg sections to the center console unit. Position the leg section next to your center console unit. Make sure they are oriented on the correct port and starboard side respectively. Refer to the recommended mounting area highlighted below.

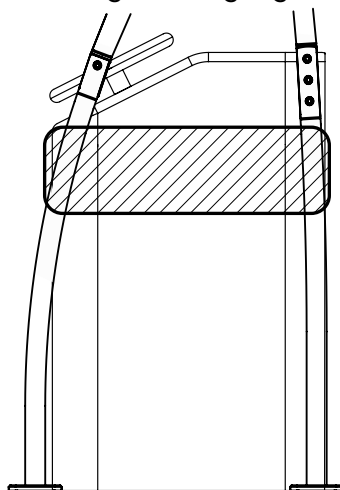

For maximum support, it is recommended that stand-offs be mounted in this area.

It is important to select an area of the console that is flat and perpendicular to the standoffs.

The distance between a leg section and the console should be between 2 to 7 inches.

The SG900 kit includes 4 stand-offs - two for each side.

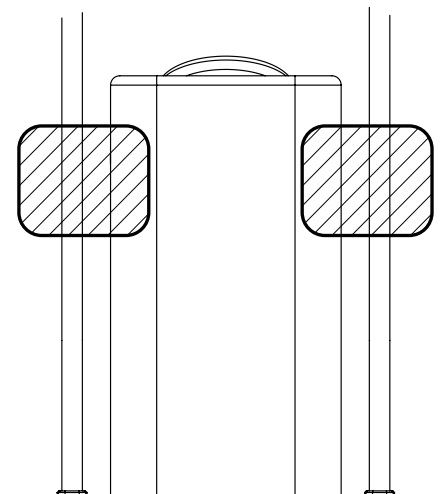

Position the lower halves of each side section on the deck. Make sure you take the same measurements from the sides and aft of the boat for each side. Legs must be parallel to each other and square.

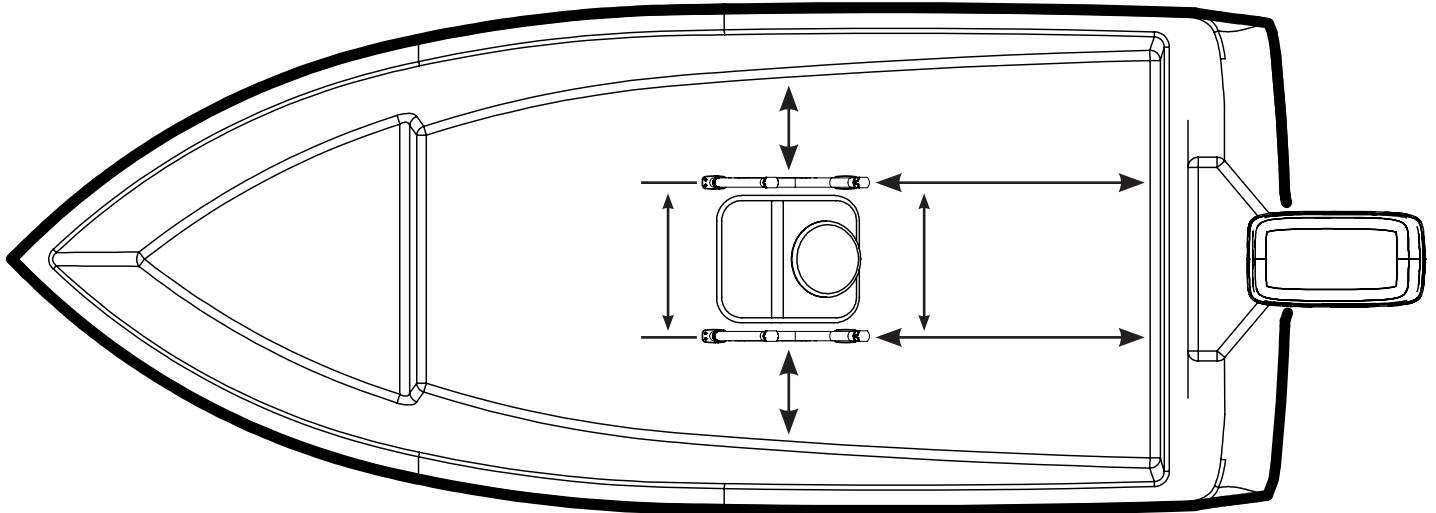

## STEP 4 MARKING MOUNTING FEET LOCATIONS

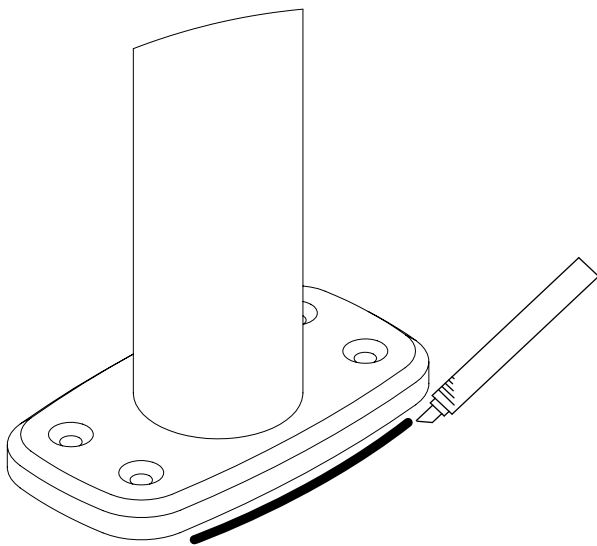

Once you have determined the best location of the leg sections and double checked all measurements, use a marker to outline each foot. Be sure you only mark on the tape placed on the deck in step 1. If using a permanent marker, be careful not to get ink on the metal feet.

Keep the line as close to the outer perimeter of the foot as possible. Later, you will need to re-align the feet with their outline to begin drilling into the deck.

Repeat the outline process for each foot.

Note: The tape will be removed just before fastening the t-top to the deck.

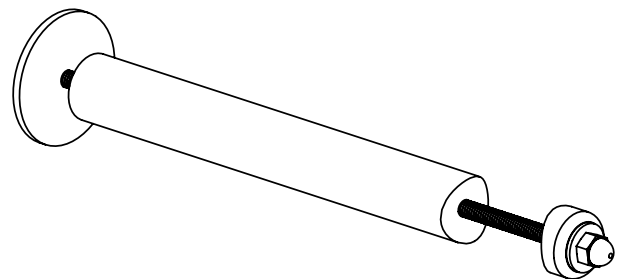

---

### *What is a Stand-Off?*

Stand-offs provide additional support needed for your t-top. They connect the legs of the t-top with your boat's center console unit on each side. You **MUST** use them!

---

## Optional Upgrade ROCKET LAUNCHERS

Probably our most popular upgrade for t-top customers who plan on fishing is one of our fishing rod rocket launchers. We offer them with 5, 7 or 9 total rod holders and in different finishes to match the t-top. We also have a model with built-in LED deck lights.

Not only are they very affordable, they are also simple to install to the top section on the forward or aft side. Just tighten down two bolts per clamp and in 10 minutes you have a sturdy place to keep your rods up off the deck and neatly out of the way.

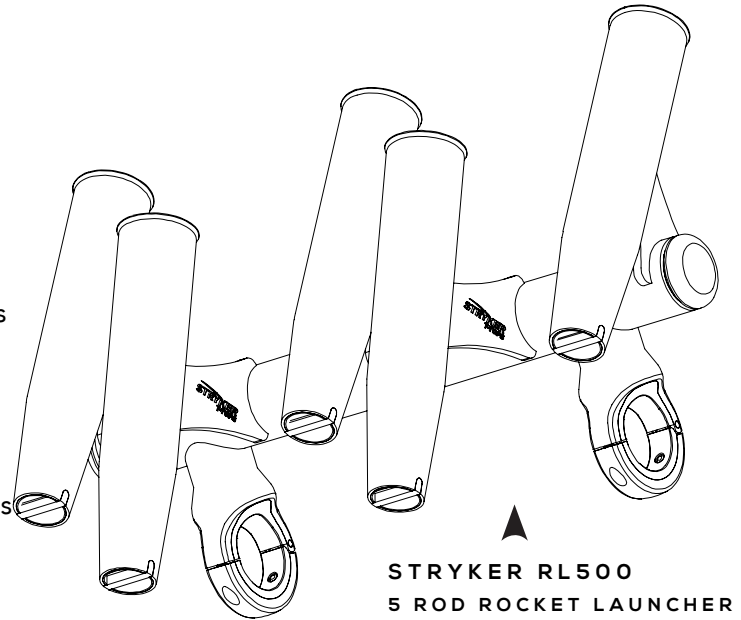

## STEP 5 ASSEMBLE THE FORWARD TOP SECTION

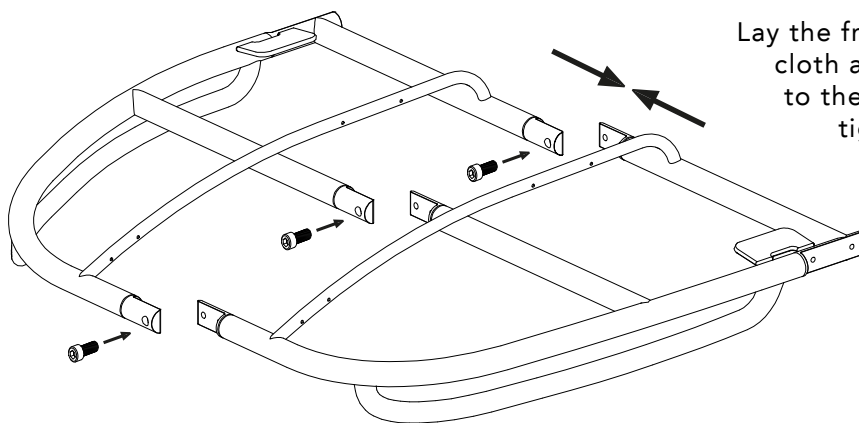

Lay the front starboard and port top sections on a soft cloth and line up the bolt holes. Apply thread locker to the threads of three top section bolts and hand-tighten to avoid cross-threading. Using an allen wrench, tighten each bolt the rest of the way.

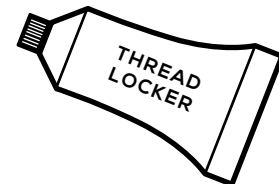

## STEP 6 FORWARD TOP SECTION MOUNTING PLATES

Follow the diagram below and bolt on one small and one large plate using the included hardware. Hold the bolt in place with an allen wrench and tighten the bolt down.

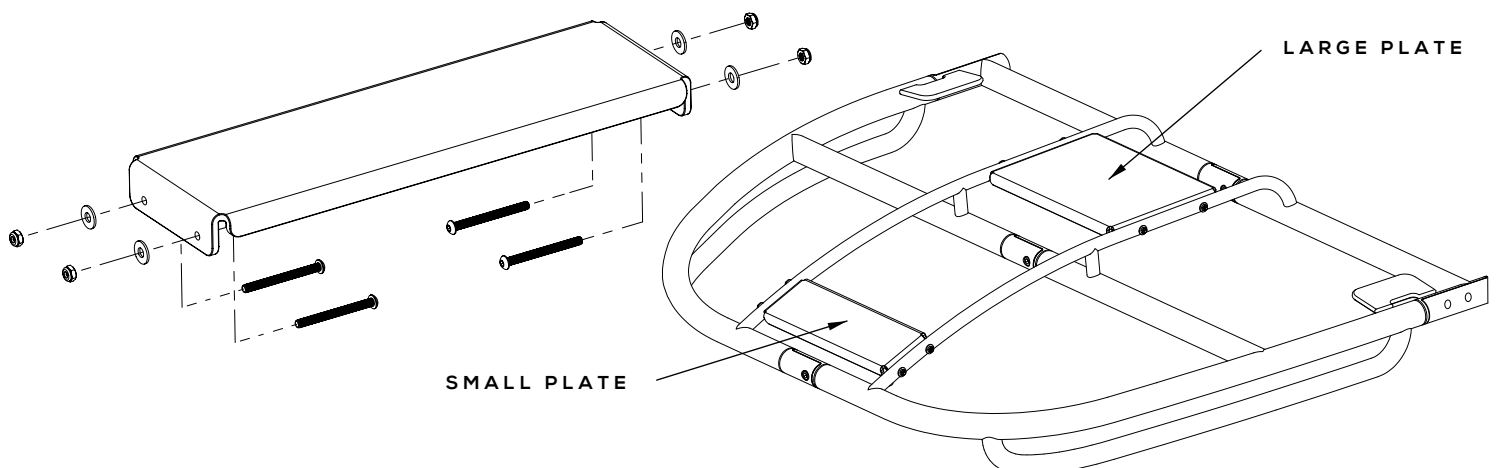



## STEP 7 MEASURE WIDTH BETWEEN LEGS

Measure and record the distance between each leg section. We recommend measuring from the inside of the left and right leg section. Since you have outlined each foot on the tape, you can use those lines for your measurement.

You will be assembling the t-top OFF the boat. You need to know how far apart to mount the leg sections to the canopy frame top section. After that, you will move the completed frame on the boat and line it up on the tape.

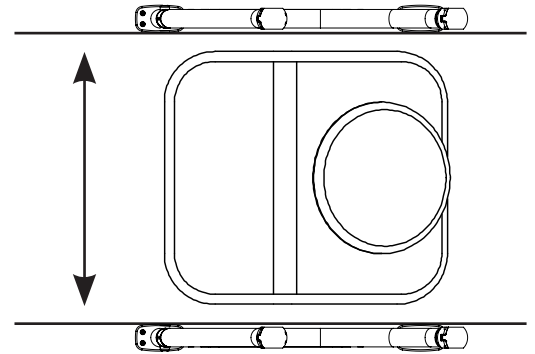

## STEP 8 ASSEMBLE LEGS TO THE TOPS SECTION

Mount the assembled top front section to the leg sections. Use two clamp bolts per clamp. Make sure the distance between the feet matches step 7. Also, compare the distance between each clamp and the outside tubing to make sure everything is centered. Each bolt needs thread locker but don't apply it until you are sure everything is positioned correctly first.

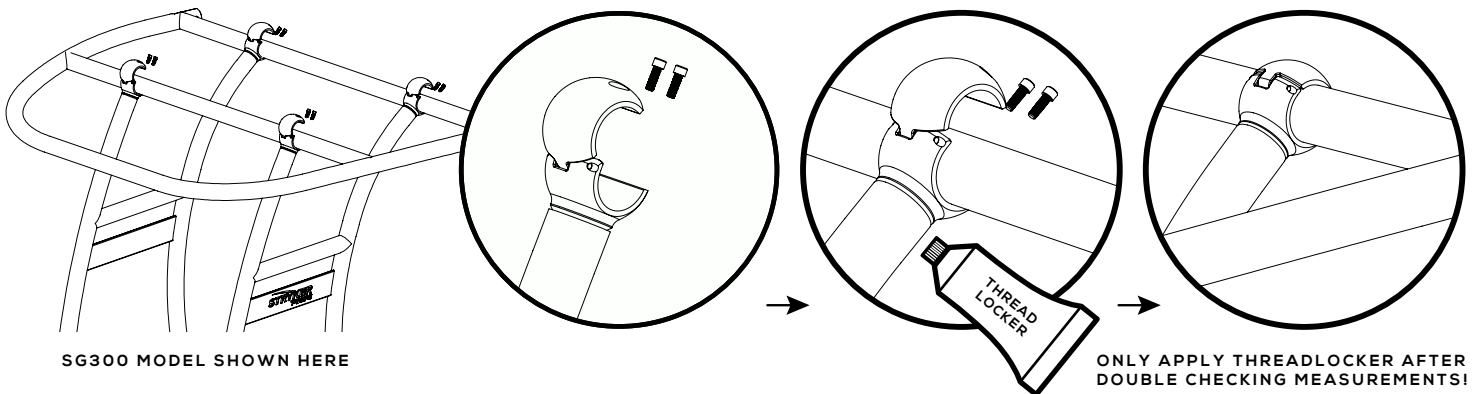

## STEP 9 SET T-TOP FRAME ON THE DECK

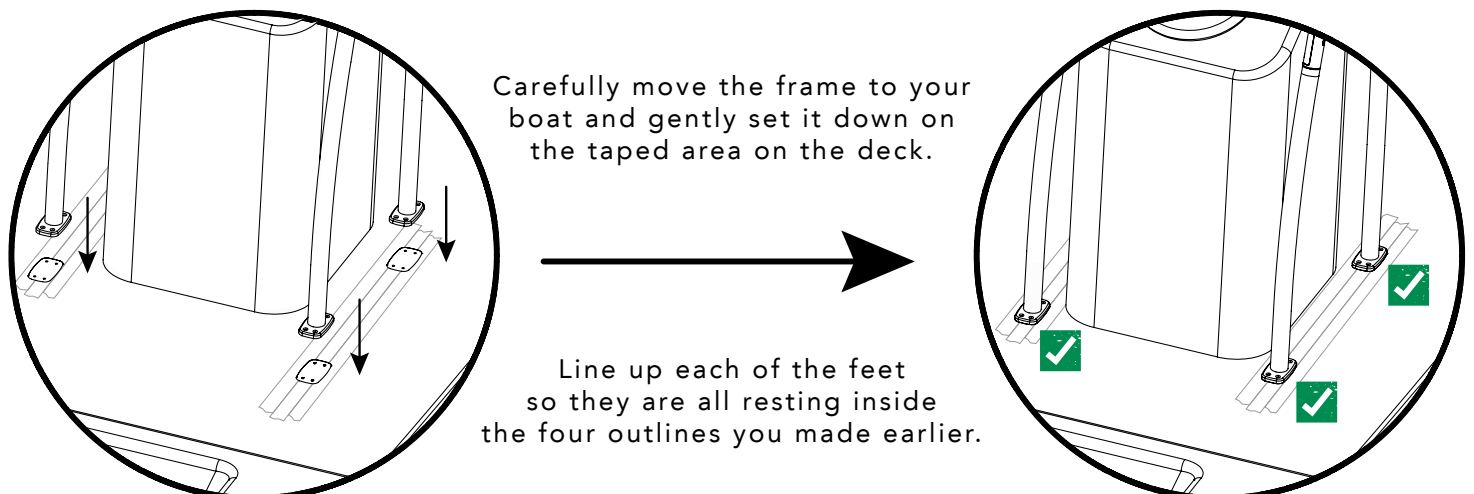

## STEP 10 DRILL MOUNTING HOLES IN THE DECK

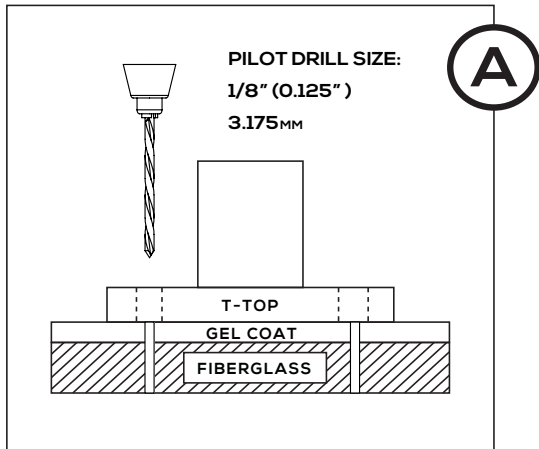

### PILOT HOLE

Before drilling, consult your owner's manual or boat manufacturer to make sure no wires, cables or tanks are directly below deck.

Do not remove the painter's tape yet.

To avoid cracking or splintering, always run the drill in REVERSE.

Using the holes on each t-top foot as a guide, drill a pilot hole with a 1/8" (0.125mm) bit.

Set the drill speed to medium and apply medium downward pressure on the drill to avoid punching through the deck.

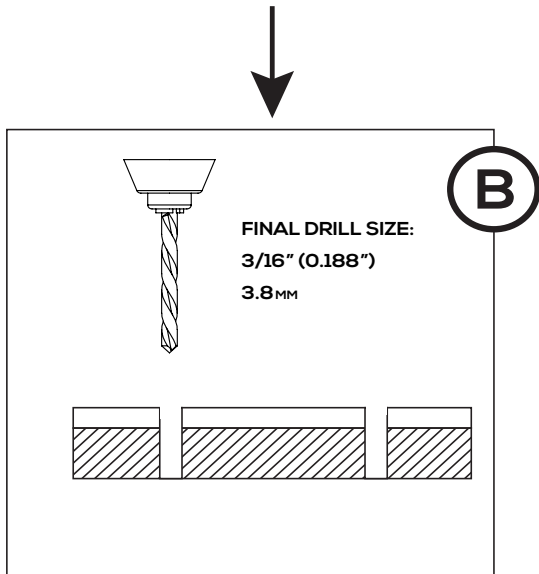

### BORE OUT TO FINAL DIAMETER

After drilling 16 pilot holes (4 per foot), move the t-top so the feet are no longer resting on the mounting location.

Bore out the pilot hole with a 3/16" (3.8mm) bit.

Do not remove the painter's tape.

Again, run the drill in REVERSE at medium speed and pressure.

Blow any dust and loose material away from the area.

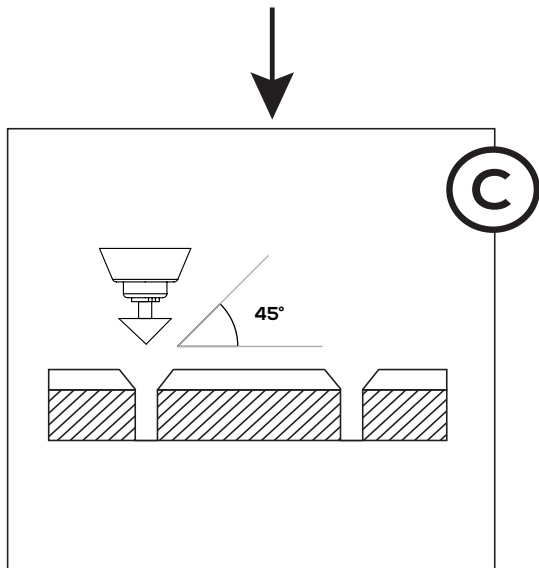

### CHAMFER HOLES

Using a 45 degree chamfer bit, countersink the gel coat on all 16 mounting holes.

Do not remove the painter's tape.

Note: Chamfering creates a pocket for the screw heads to sit in. This will greatly reduce any outward pressure from the angled screw head that could cause spider cracking of the gel coat.

Blow any dust and loose material away from the area.

## STEP 11 MOUNT T-TOP TO THE DECK

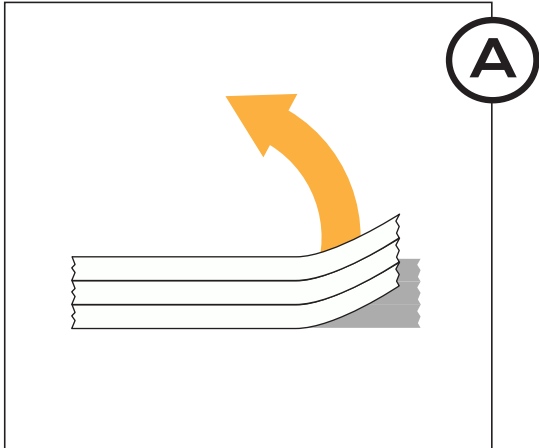

It's time to mount the t-top frame to your boat's deck.  
Prepare the deck so it's cleared out and ready.  
Remove the painter's tape from both sides.  
Clear the deck of any debris and dust.

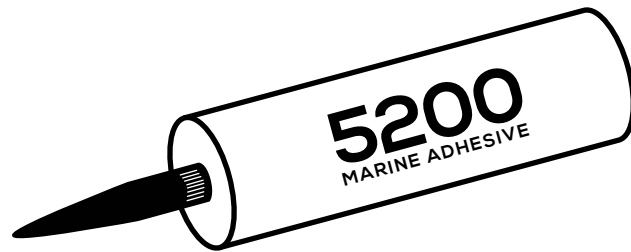
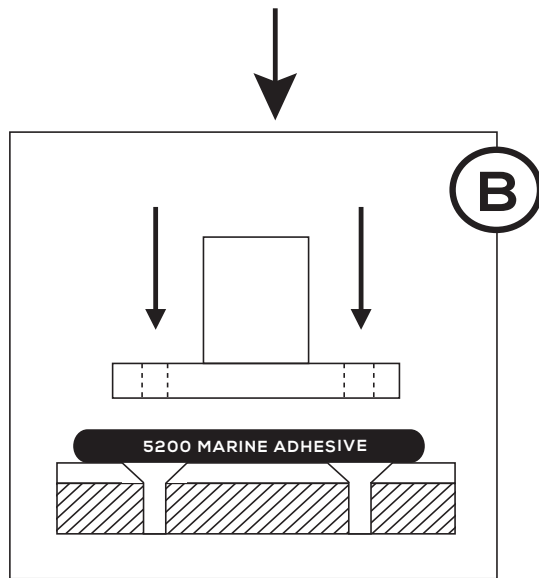

Apply a generous amount of marine grade sealant on the deck matching the contact patch of the mounting feet.  
We recommend 3M 5200 Marine Adhesive or equivalent.

Reposition the t-top over the sealant and gently lower it into place while avoiding side-to-side movement.

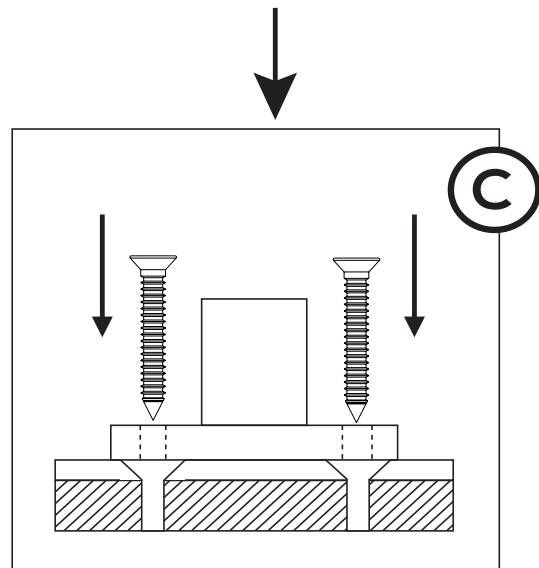

Using a phillips head bit, screw down and tightly fasten the mounting feet to the deck of the boat.

Circle back to each screw to make sure they are each torqued down all the way but avoid stripping out the deck.

Using a wet cloth, remove excess sealant around each foot.

Remember to check the 5200 adhesive label for recommended cure times specific to your local temperature and humidity.

## STEP 12 MOUNT STAND-OFFS

From step two of this installation guide, you should have already determined where to mount your stand-offs.

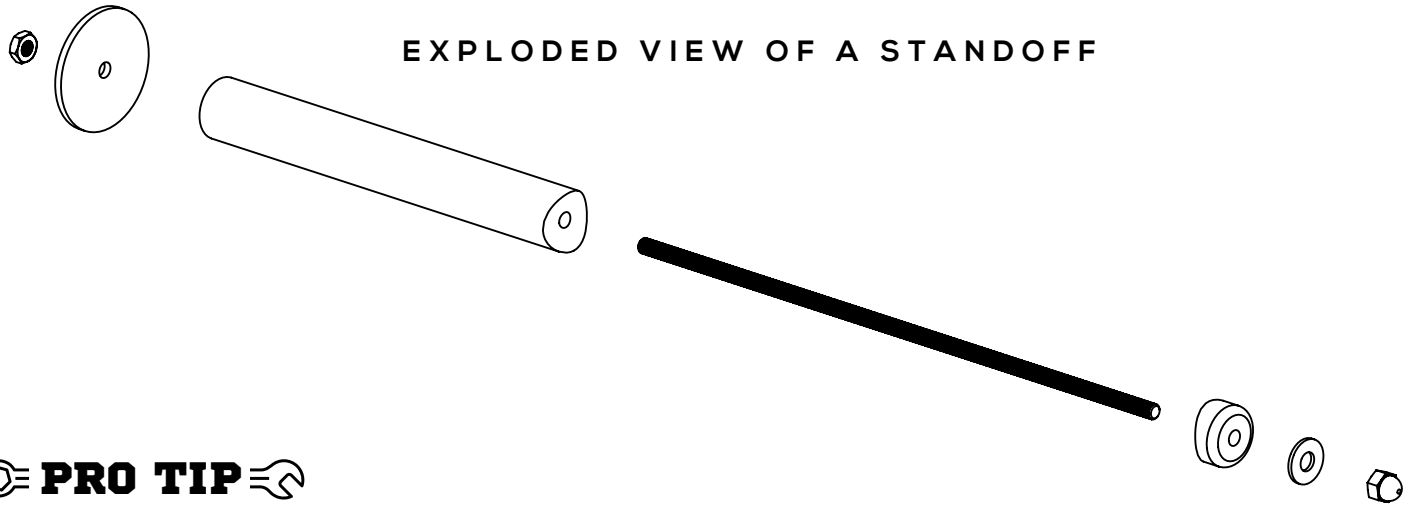

### PRO TIP

Check the thickness of your console's side walls. If they are thin or bend easily with a little pressure, we advise adding a backing material like marine-grade plywood on the inside. Cut it to fit the largest area you can.

By minimizing any side wall flex, you will decrease the side-to-side movement of the stand-offs and the t-top.

Also, be sure you have access to the inside of the console unit so that you are able to tighten the bolts.

## MEASURE LENGTH NEEDED FOR STAND-OFFS

The stand-offs will need to be cut to length. These steps will help you know exactly how long to cut them.

From the mounting locations you have chosen, measure the width of the space between the outer surfaces on the console unit to the closest point of the t-top. (See figure A)

You will want to repeat the process on both sides just in case there is a slight difference in distance.

On the tubing of the t-top and on the console, mark the mounting locations and drilling spots. (See figure B)

Note that the size and shape of your console unit and your preference on where the t-top looks best will affect stand-off mounting options.

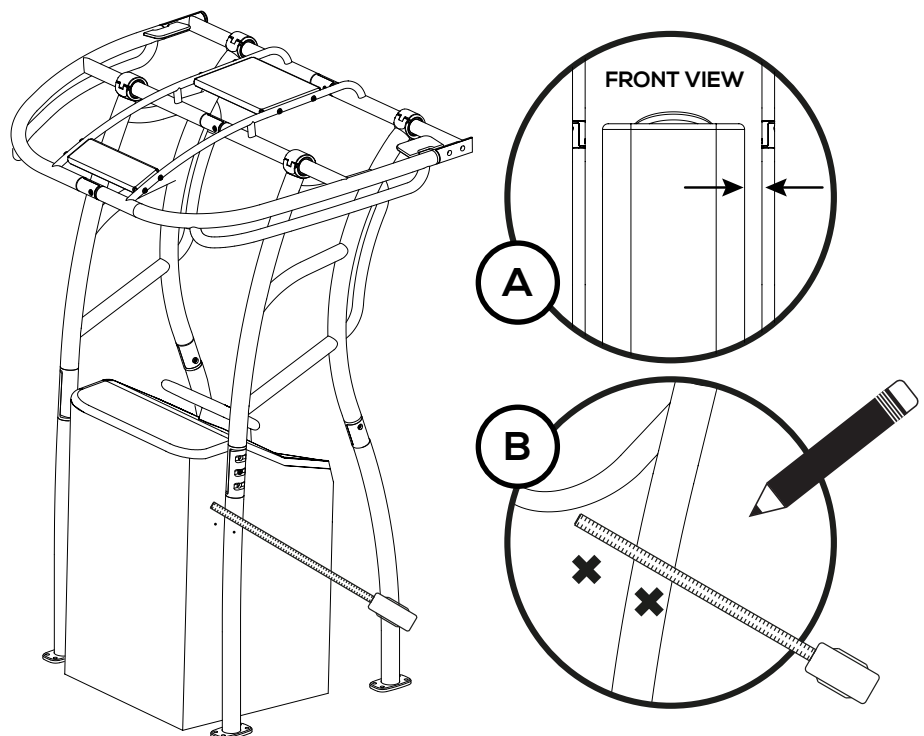

## STEP 12 MOUNT STAND-OFFS (CONT.)

### MARK CUT LINE ON STAND-OFFS

Transfer the measurements from the previous step by marking each stand-off with a cut line.

If your left and right side have different lengths, we recommend sticking a little painter's tape on each and noting which is which.

Notice how one end of the stand-off is concaved. That curve mates with the outer curve of the tubing. Be sure to not cut it off!

Also, when measuring to draw the cut line, make sure you measure from the lowest part of the concave- it matches the outermost point on the tubing you are mounting it to.

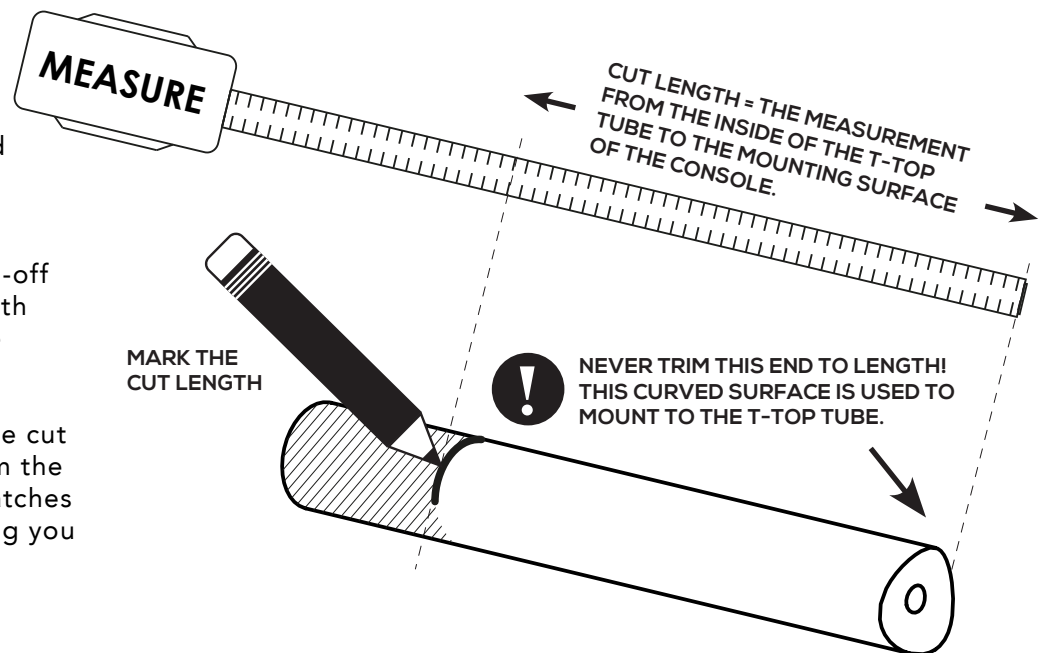

### CUT STAND-OFFS TO LENGTH

Using a hacksaw, cut along the marked line. For the straightest line, a simple miter box works great. We recommend using new blades that are designed specifically for cutting through solid aluminum.

### PRO TIP

We recommend starting with a higher TPI blade to start the initial cut. Then, switch to a lower TPI blade for the remainder of the cut. A lower TPI blade has more resistance and will "hook on" or get stuck frequently until a groove has been established.

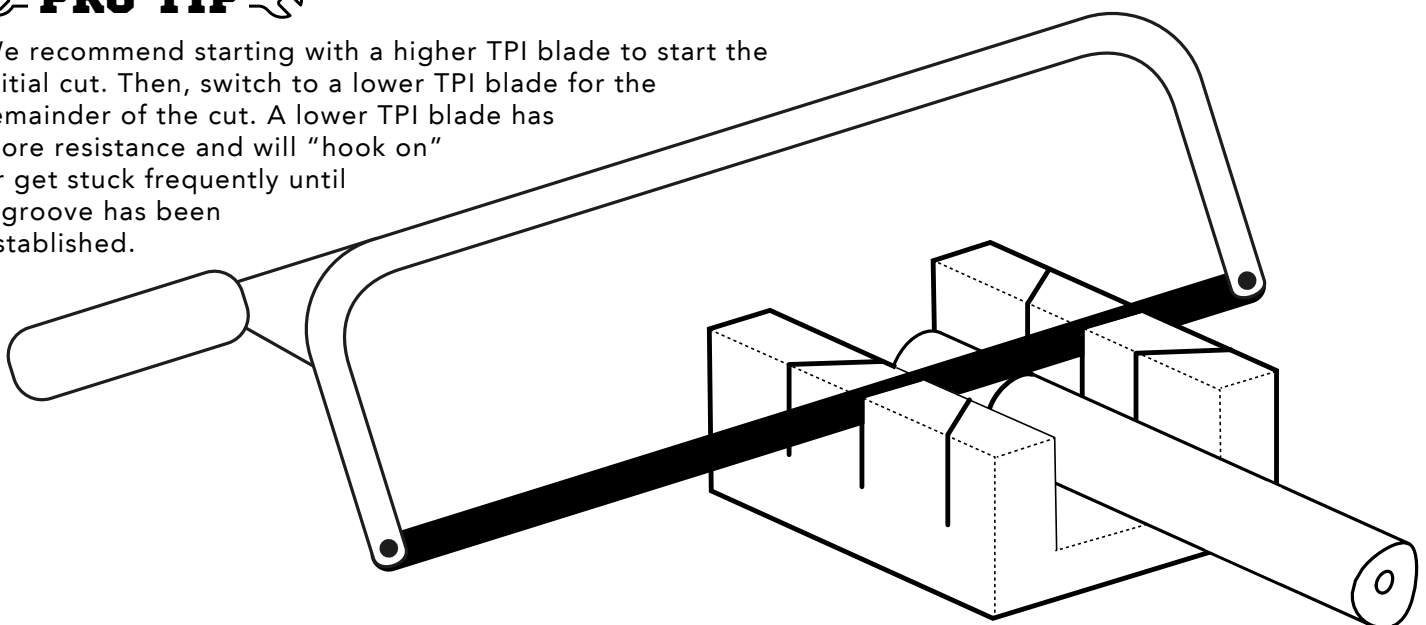

## STEP 12 MOUNT STAND-OFFS (CONT.)

### DRILL THROUGH T-TOP & CONSOLE

Drill through the marked locations on the t-top and on the console. Make sure all holes are straight and aligned with each other so that the threaded rod can pass easily through.

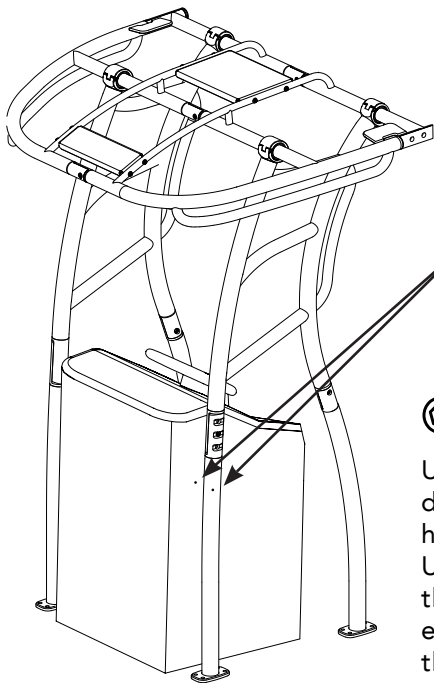

EXAMPLE OF DRILL HOLE LOCATIONS

#### **PRO TIP**

Use a center punch to create a dimple on the tubing. This will help keep the drill bit in place. Use a standard drill bit to bore through the tubing then run an extra-long drill bit all the way through the center console to get perfectly aligned holes.

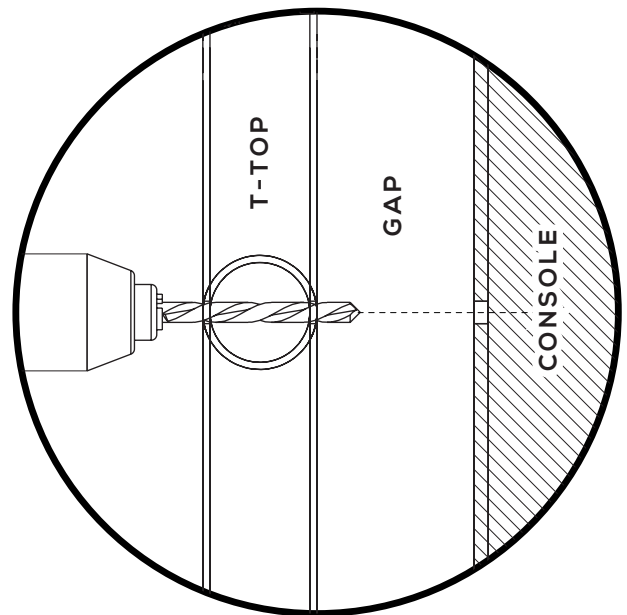

### MOUNT STAND-OFF HARDWARE

Assemble all the stand-off parts and hardware as shown below. You will need two wrenches or sockets to hold and tighten the outer and inner nuts at the same time. Repeat the steps for both sides.

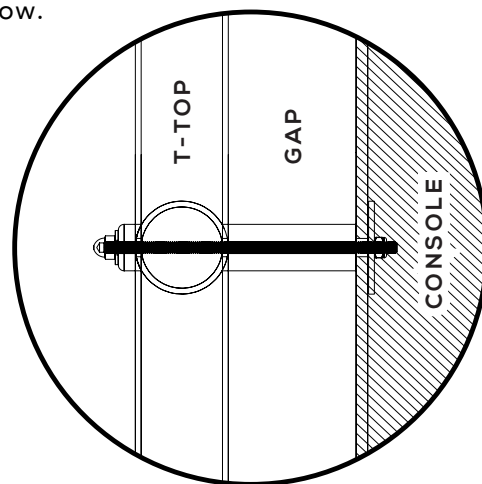
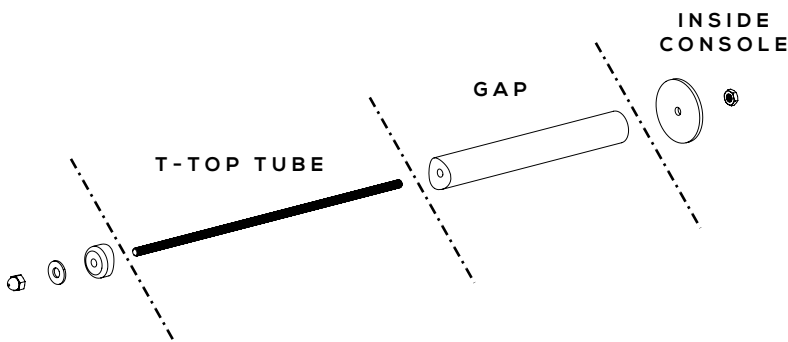

2 WRENCHES OR  
SOCKETS NEEDED  
TO TIGHTEN NUTS

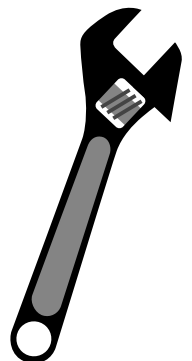

## Optional Upgrade T-TOP V-BRACE KIT

For those who have choppy local waters or would like to reinforce their t-top, Stryker has designed the V-Brace kit as an optional add-on. It diagonally connects the forward facing legs with the front side of the center console with solid clamps and thick aluminum bars.

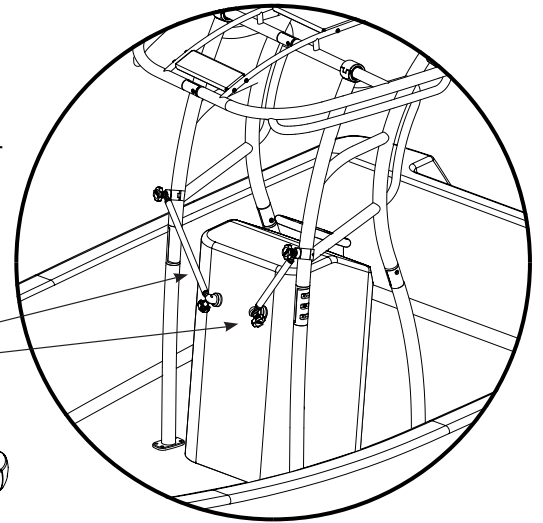
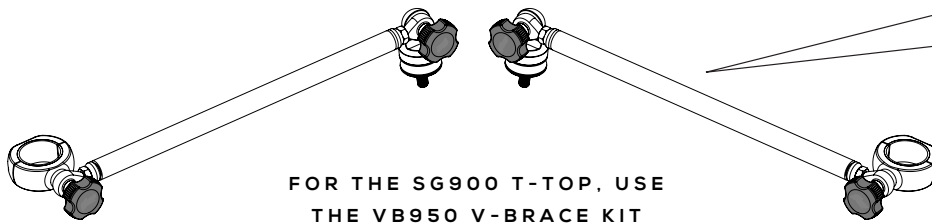

## STEP 13 ASSEMBLE REAR TOP SECTION

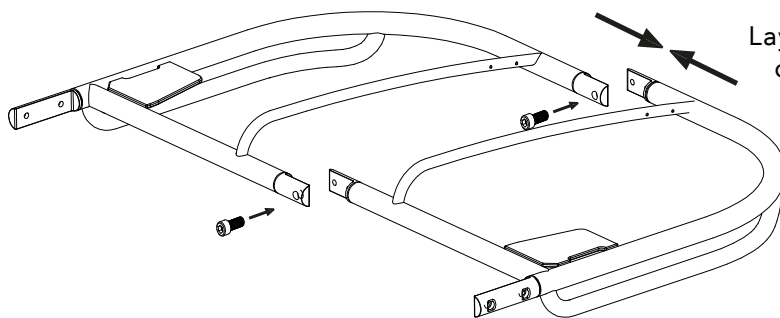

Lay the rear starboard and port top sections on a soft cloth and line up the bolt holes. Apply thread locker to the threads of two top section bolts and hand-tighten to avoid cross-threading. Using an allen wrench, tighten each bolt the rest of the way.

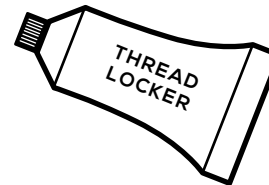

## STEP 14 REAR TOP SECTION MOUNTING PLATE

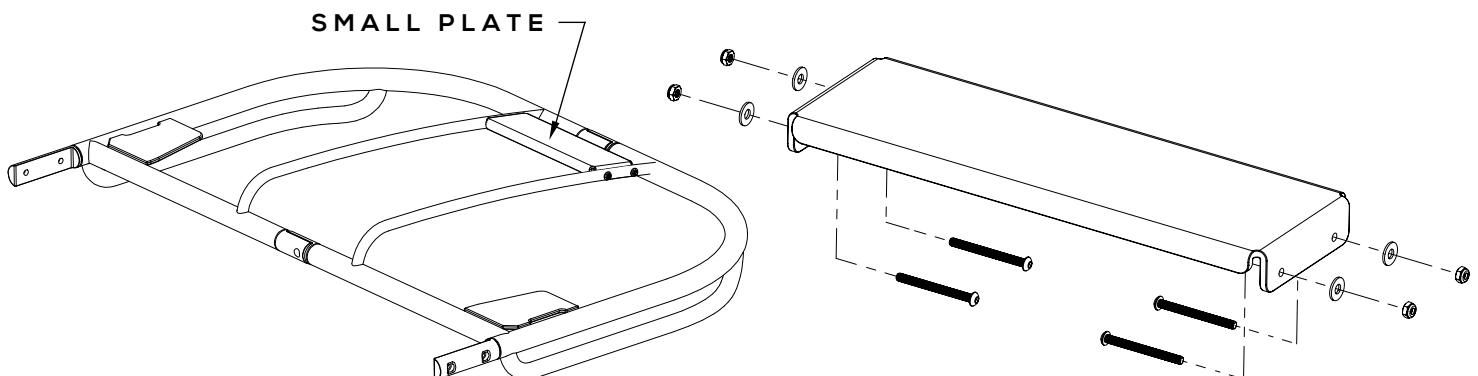

## STEP 15 MOUNT REAR TOP SECTION TO T-TOP

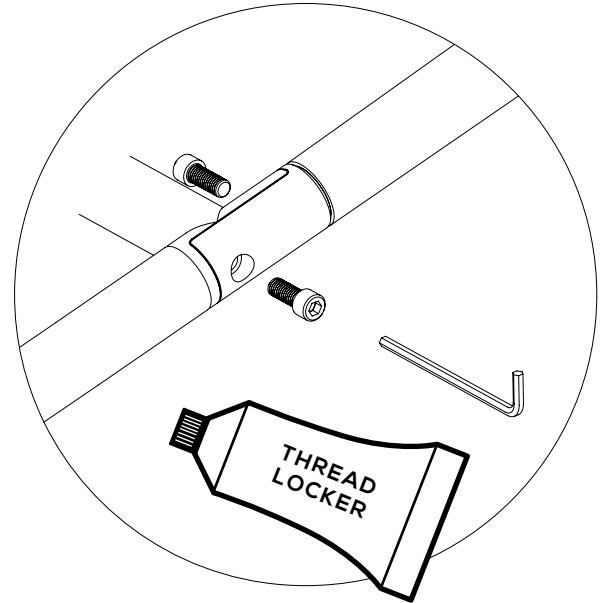
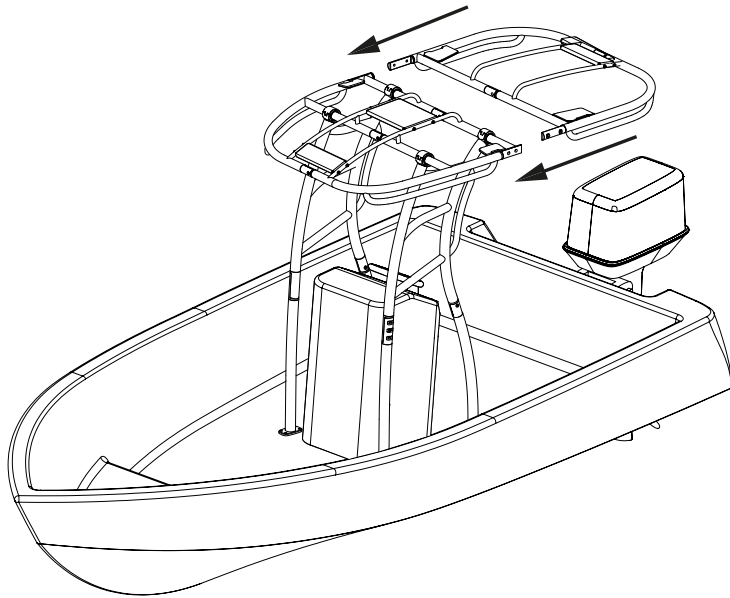

## STEP 16 LAY CANOPY IN PLACE

Lay the canopy out flat on the top frame. To help keep it in place, zip tie the canopy down at least every third grommet hole. The edge of the canvas will sit inside the top frame with a slight gap in between.

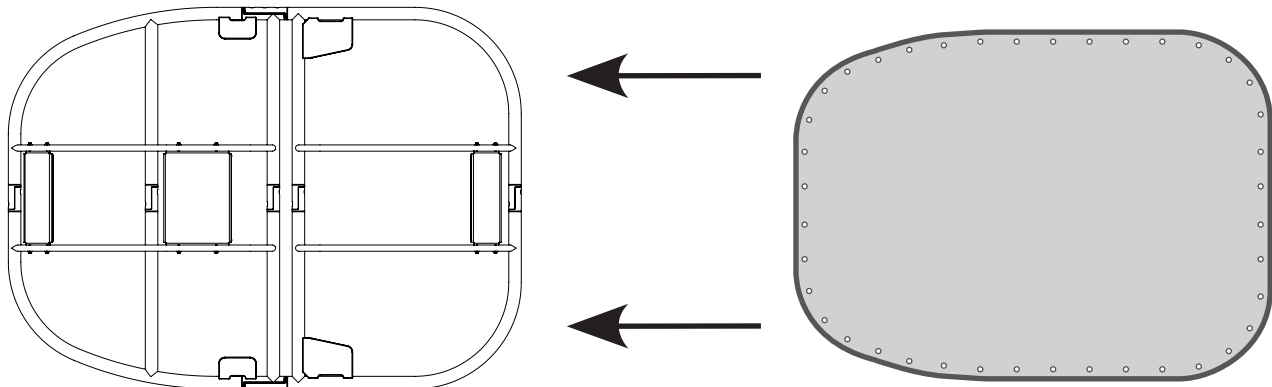

ZIP TIE THE CANOPY IN PLACE AT LEAST EVERY SECOND OR THIRD HOLE TO MAKE ROPING EASIER.

REMOVE ZIP TIES AFTER THE CANOPY IS COMPLETELY ROPED ON AND DRUM TIGHT.

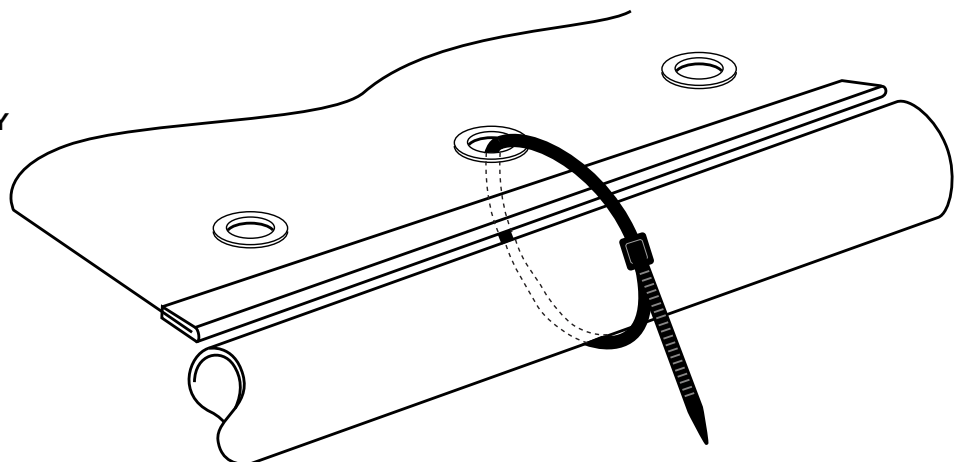



## STEP 17 ROPE THE CANOPY

Start with a knot at the rear of the top to keep the cord in place. Follow the diagram below to secure the canopy through each successive hole. After the final hole, go back through each loop to remove any excess slack to tighten it down as much as possible. Complete the process by tying a final knot. The canopy should be drum-tight with just a little gap between the outer edge of the canvas and the inside of the top's tubing.

### PRO TIP

A drum-tight canopy will extend the fabric's life by avoiding damage from excessive wind movement and by allowing water to roll off instead of pooling up which can stretch, sag and weaken the material.

TIE A KNOT AT EACH END TO START AND STOP THE CORD

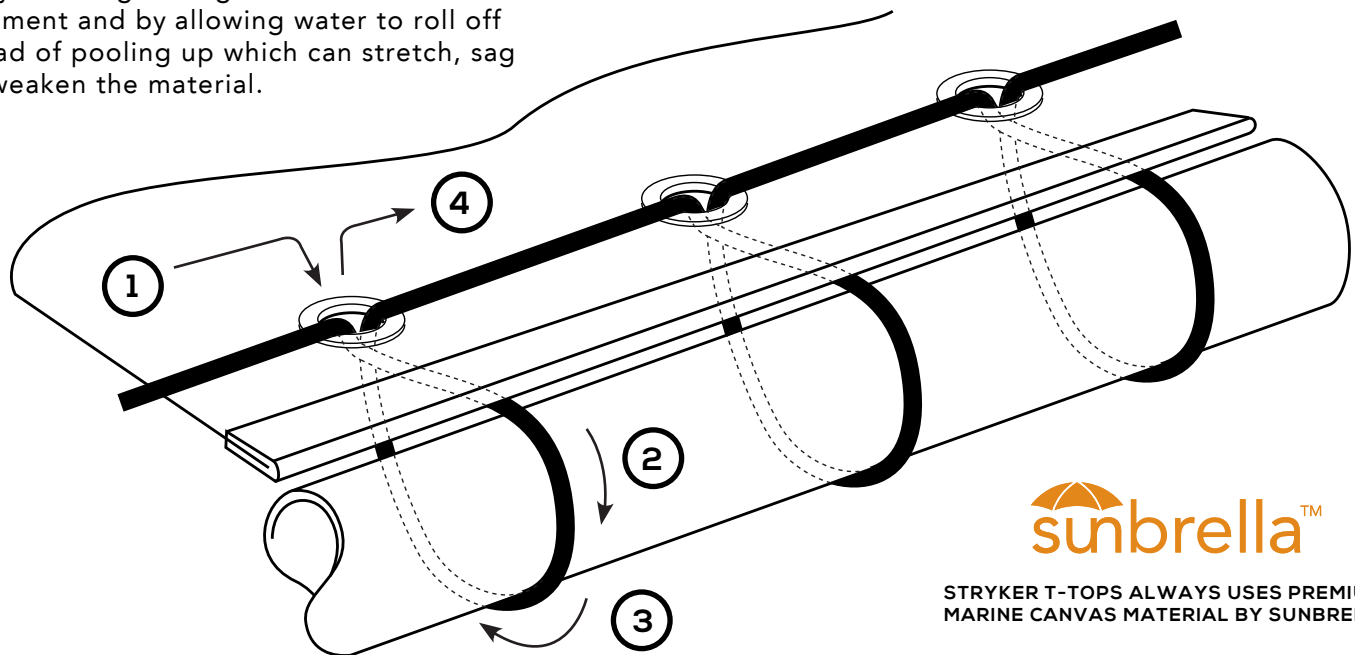
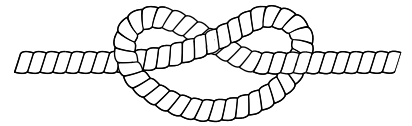

 sunbrella™

STRYKER T-TOPS ALWAYS USES PREMIUM MARINE CANVAS MATERIAL BY SUNBRELLA

# Installation Complete!

CONGRATULATIONS ON FINISHING YOUR STRYKER T-TOP INSTALLATION

## Add Your Boat to Our Customer Gallery!

After you have installed your Stryker T-Top, take some photos and send them to us. We'll add your boat to our customer photo gallery, send you a free tee shirt and enter you into our regular drawings for big prizes! We love seeing scenic photos out on the water and active fishing shots. Simply complete the gallery form on our website at <https://strykertops.com/submit-customer-gallery>

You can also post photos of your boat with a Stryker T-Top installed using the hashtag #mystrykertop

## Proper Usage & Safety

For your safety and everyone else, plus, to avoid damage to your Stryker T-Top and boat, please read and observe the following. Make sure all bolts and screws are properly torqued down. Over time, vibrations can loosen them up so it is important to retighten everything periodically. Do not use the t-top to tow wakeboarders, skiers, knee boarders, inflatables or tubes. Do not trailer your boat with the t-top folded down. When trailering your boat, make sure it is in the upright position and pay close attention to clearance limitations like low bridges, car port covers, tree branches, etc. Be sure to measure the highest point of your t-top or mounted accessories before hitting the road.

Do not attempt troll fishing with lines or rods cast from the t-top. When the boat is in motion either in the water or on a trailer, be sure to take down any rods, outriggers or other items that might conflict with clearance heights on your route. Stryker T-Tops is not responsible or liable for damage due to a customer's misuse of our products or negligence.

## Wiring Instructions

You can easily wire your Stryker T-Top to connect lights, antennas, speakers or other electronics. The frames are hollow and are a perfect place to keep wires tucked out of sight and away from the elements. Careful planning will help you avoid the cleanest installation without unnecessary drilling or miscalculations.

Start by drilling a hole where you want the accessory mounted to the tubing. If mounting to the top "hoop" section that the canvas ties to, start by feeding the wire into the tubing at that location. Work the wire through towards the middle of the top sections where the leg sections clamp. The clamps are solid billet aluminum but have a predrilled hole for wires. This is how you will get the wires down towards the deck. Drill an exit hole in the top section that is in line with where your clamps are located.

Note: you will have to have your t-top completely installed to know exactly where your leg section clamps will be located relative to the top section.

Once aligned, you can feed the wire exiting the top section down through the middle of the leg section clamps. Continue working the wires down the leg section closest to the bow. Be sure to plan ahead, know where the terminals on the boat are located and know if it's better for you to run wires down the port or starboard leg.

The most important thing to know is that the joints that connect the top and bottom leg sections are solid billet aluminum and must be bypassed. They are not pre-drilled like the top clamps. Do not attempt to drill through these sections as it could compromise the strength of the joints.

To bypass them, you will need to drill an exit hole and re-entry hole around the joint. Make a 1" hole about 1.5" away from the weld line. To keep water out, we recommend picking up some rubber grommets that fit the holes you are drilling. Also, give yourself a little extra slack in the bypassing wire especially if you have a t-top model that folds. This is another good reason to run the wires down the leg section tubing closest to the bow since that is the folding joint on certain models.

Lastly, most of our customers exit the wire out of the bottom of the leg section with one more drilled hole and another rubber grommet. From there, you can run the wire to where you need to connect it. Once everything is complete, we recommend putting a little silicon caulking on the rubber grommets around the wire to prevent water from getting inside the tubing.

## Folding Your T-Top Down

For t-top models that feature a folding capability, please make sure you are following the correct steps. First, only collapse the t-top when you need to minimize vertical clearance to either safely navigate under a low bridge on the water or to fit your boat in a garage or other storage location. Do not trailer your boat with the t-top folded down. Driving on roads this way could allow the unsecured folded top section to sway and bend parts of the lower leg sections and possibly crack the welds of the frame.

Remove the two rear leg bolts on each side. On the front of each leg section, there are three bolts per side. Only remove the top and bottom bolts. When the top folds forward, it uses the remaining single center bolt on each side as a hinge. With another person, gently tilt the top section forward towards the bow until it is gently rested on the deck. We highly recommend purchasing some of our Quick Release Knobs to make the process easier. They replace the standard allen head bolts with large gripped bolts you can loosen or tighten by hand. Repeat the process in reverse to bring the t-top back up and make sure to properly tighten all bolts.

## Center Console Units with a Hinged Door

If your boat's center console unit has a hinged door, you should carefully measure the size and clearance required to fully open it. Depending on the Stryker T-Top model, the lower leg sections might have a horizontal brace that could prevent the door from opening. On the SG300, this brace is welded on; the SG600 has a brace that is mounted with allen head bolts and can be temporarily removed; the SG900 has been designed with a much higher horizontal brace to avoid this situation.

Probably the simplest solution, some of our customers have replaced their door hinges with pins. This allows the door to be pulled out without swinging it open. However, you will still need to consider how the horizontal brace will affect your access to the inside of the console unit. Please contact us with your door's measurements so we can help figure out the best solution based on your needs.

## Care & Maintenance

Properly cleaning your Stryker T-Top products will greatly extend the life and maintain their value! We recommend more frequent light cleaning. This will avoid a build-up of grime and deposits that will require stronger cleaning and harsher cleansers.

### GENERAL CLEANING TIPS

- Over-cleaning or excessive rubbing can do more harm than good.
- To prevent marring, make sure your sponges, microfiber cloths, pads, etc, are clean and grit-free.
- Only use clean water. Dump and refill bucket regularly to remove abrasive dirt and contamination.
- Avoid abrasive or household cleaners that can cause permanent damage to painted surfaces.
- Avoid abrasive materials such as steel wool, scouring pads, hard bristle brushes, etc.
- When using recommended solutions avoid drips and splashes. Remove run downs as quickly as possible.
- Avoid temperature extremes. Heat accelerates chemical reactions and may evaporate water from solution. Extremely low temperature may give poor cleaning effects. Cleaning under adverse conditions may result in streaking or staining. Ideally, cleaning should be done in the shade at a moderate temperature.
- Do not substitute a heavy duty cleaner for a frequently used mild cleaner.
- Do not scour painted surfaces.
- Never use paint removers, aggressive alkaline, acid or abrasive cleaners.
- Always do a test on a small hidden area before treating the entire surface.
- Follow the manufacturer's instructions for applying, mixing, diluting, etc.
- Never mix cleaners.

## Care & Maintenance (continued)

### **ANODIZED ALUMINUM CARE**

You can save yourself a lot of time and unnecessary extra effort by simply committing to a regular, stress-free cleaning regimen. Frequent light cleaning goes a long way to avoiding deposit build-up, etching or other ugly conditions that require lots of elbow grease and harsher cleaning methods.

Start by determining the condition of the surface and how long it has been since the last cleaning.

If it's just dirty, you can wash down anodized aluminum with a mild soapy solution or with warm water containing a suitable wetting agent. Rinse with clean water and dry everything with a clean micro fiber cloth.

Because anodizing creates a hard finish, mild abrasives or an abrasive cleaning sponge is sometimes recommended. More difficult grime deposits may also require the use of a mild abrasive.

BE VERY CAREFUL with whatever you use for medium to heavy cleaning! Start with a small hidden spot. Make sure the surface is cool, out of direct sunlight and always follow the instructions on the bottle. Some of our customers have had success using either Woody Wax Kit <http://www.woody-wax.com/woody-wax-kit.php> or Flitz Liquid Polish: <https://www.flitz.com/flitz-polish-liquid/>

DO NOT use harsh acidic or alkaline cleaners because they may destroy the finish permanently. Use solvents with care as they may stain, discolor or erode the finish. Remember to be thorough and clean all surfaces, all sides, all corners and every nook. Also, thoroughly rinse with clean water especially where crevices are present to ensure removal of all residues. If improperly rinsed, residual cleaning agents can lead to etching or discoloration. Dry everything with a clean micro fiber cloth.

For more difficult condition issues, please either contact us or your local professional.

### **POWDER COATING CARE**

You can save yourself a lot of time and unnecessary extra effort by simply committing to a regular, stress-free cleaning regimen. Frequent light cleaning goes a long way to avoiding deposit build-up, etching or other ugly conditions that require lots of elbow grease and harsher cleaning methods.

The best method of cleaning any powder coated finish is by regularly washing it using a solution of clean water and a mild detergent. The entire surface- including all the nooks and corners- should be cleaned using a soft cloth or sponge, using nothing harsher than a natural bristle brush. This will remove any dirt, minerals and residue that could scratch or etch the finish. Rinse with clean water and dry with a micro fiber cloth.

If the atmospheric pollution has resulted in heavy soiling of the coating that is difficult to remove, then nothing harsher than white spirit should be used for cleaning. Make sure the surface is cool and out of direct sunlight. Always test in a less visible spot before treating the entire surface.

DO NOT use abrasive pads, steel wool or other hard textured mediums because they could permanently destroy the finish. There are a variety of "powder coating polish" products on the market that are specifically designed to polish and protect. Carefully follow the manufacturer's instructions.

For more difficult condition issues, please either contact us or your local professional.

## Warranty Information

**WE TAKE PRIDE IN THE QUALITY OF OUR MANUFACTURING PROCESS AND MATERIALS. WE INSPECT EVERY PRODUCT BEFORE IT IS SHIPPED TO ENSURE OUR STRICT STANDARDS ARE MET.**

Stryker's 5 year warranty starts from the purchase date and covers defects that have occurred during the manufacturing process. Following a physical inspection that determines a valid warranty claim, Stryker will- at its discretion- replace, send replacement parts or reimburse for the repair of any eligible products. The anodized or powder coated finish and hardware are excluded from the warranty coverage. Stryker is not responsible for personal injury, boat damage or equipment loss directly or indirectly related to our products. This warranty does not cover damage due to acts of God (fire, flood, lighting, etc.) nor product misuse and accidental damage. Any cost of shipping and installation related to the return and replacement of products is the responsibility of the customer unless otherwise deemed by Stryker. Stryker T-Tops disclaims any warranty of merchantability or fitness for a particular purpose in connection with the Buyer's purchase of units of any Product under this agreement. For any products we sell but do not manufacture, that product's manufacturer warranty applies and RMA requests must be made with them.

Defects must be reported within 30 days from the receipt of purchase.

Your new product was manufactured and assembled to meet the strict quality standards of the original manufacturer. We ship thousands of products every year to customers who are very happy with the quality and craftsmanship of our products.

Due to the nature of aluminum and stainless steel manufacturing and welding, some minor blemishes, scratches and/or nicks may be visible on the product. **SUCH MINOR BLEMISHES, SCRATCHES AND/OR NICKS ARE NORMAL AND ARE NOT A VALID REASON TO RETURN A PRODUCT.** If you believe that your product shows excessive blemishes, scratches or nicks, you must send us an email within 3 days stating your concern. **DO NOT WAIT TO INSPECT YOUR PARTS!** Your email must include photographs that clearly shows the size, pattern and location of the blemish, scratch and/or nick.

As you are unboxing all the product parts, be very careful not to misplace any small parts or hardware.

All Stryker T-Tops and accessories have been carefully designed, manufactured and tested to meet the highest standards of quality and performance to be extremely well-suited for a specific purpose. If any product is found to have been modified, altered, incorrectly installed, mistreated, neglected, improperly maintained, used for purposes it was not originally intended for or used beyond its physical limitations of design or material, any and all warranties will be deemed void. The warranty period shall not be extended by the replacement of materials under this warranty but the remaining warranty period shall continue in effect and be applicable to the replaced or repaired products or component parts areas under conditions of the warranty.

THIS LIMITED WARRANTY IS IN LIEU OF ALL OTHER WARRANTIES, EXPRESS OR IMPLIED, INCLUDING, BUT NOT LIMITED TO, THOSE CONCERNING MERCHANTABILITY OR FITNESS FOR A PARTICULAR PURPOSE. THIS LIMITED WARRANTY IS ALSO IN LIEU OF ANY OTHER POSSIBLE LIABILITIES OF THE SELLER OR MANUFACTURER, WHETHER ALLEGED TO ARISE BY AGREEMENT OR BY OPERATION OF LAW. RESPECTING THE SALE , APPLICATION, USE OR FUNCTION OF PRODUCTS, INCLUDING BUT NOT LIMITED TO CLAIMS OF NEGLIGENCE, GROSS NEGLIGENCE, STRICT LIABILITY OR ANY OTHER TORT. IN NO EVENT SHALL THE SELLER OR MANUFACTURER BE LIABLE FOR PERSONAL INJURY OR PROPERTY DAMAGE, REAL OR PERSONAL, ATTRIBUTED TO ITS PRODUCTS, NOR FOR ANY EXCAVATION, REMOVAL, REAPPLICATION, DOWNTIME, CLEANUP, LOSS OF USE, LOSS OF OPPORTUNITY, LOSS OF MARKET VALUE, LOSS OF RENTAL VALUE OR FOR ANY LOSS OF PROFITS OR OTHER SPECIAL, INCIDENTAL, RESULTING, CONSEQUENTIAL OR EXEMPLARY DAMAGE.

## Product Returns

Goods can be returned by the ORIGINAL PURCHASER at their expense within three (3) days of the date of DELIVERY with no questions asked for a full refund of the purchase price (less shipping, labor, special order, and non-certified funds charges) provided the product(s) are in original new condition, in their complete original packaging and have not been installed.

If for any reason you're dissatisfied with your purchase, we will replace the product or refund your purchase price within 30 days of purchase date from [strykerttops.com](http://strykerttops.com). Note that returns must be in original packaging and in new, resalable condition otherwise a 25% restocking fee will be added. Damaged or unsalable products will not be accepted. All packaging, shipping and insurance costs incurred to return products to Stryker T-Tops are the responsibility of the purchaser and will not be credited. Original shipping fees paid for shipping to the customer are non-refundable.

All customer shipping charges are non-fundable. Customers are responsible for any shipping charges incurred for returns or exchanges. Customer will be billed for any additional shipping charges incurred for refused shipments.

Prior to returning any products to Stryker T-Tops for a return or replacement, please fill out the form at [www.strykerttops.com/warranty-returns](http://www.strykerttops.com/warranty-returns). If you are requesting to return multiple products, please complete a form for each product. We will contact you via email within 2-3 business days with further instructions.

## Contact Us

If you have any additional questions, please don't hesitate to contact us. Our team is always available to help you before your purchase, during the installation and for the lifetime of ownership.

**Stryker T-Tops**  
23482 Peralta Drive Suite B  
Laguna Hills, CA 92653

**(949) 407-5000**

[sales@strykerttops.com](mailto:sales@strykerttops.com)  
[support@strykerttops.com](mailto:support@strykerttops.com)