

# STRYKER T-TOPS

## SWITCHBACK LEANING POST (LP200)

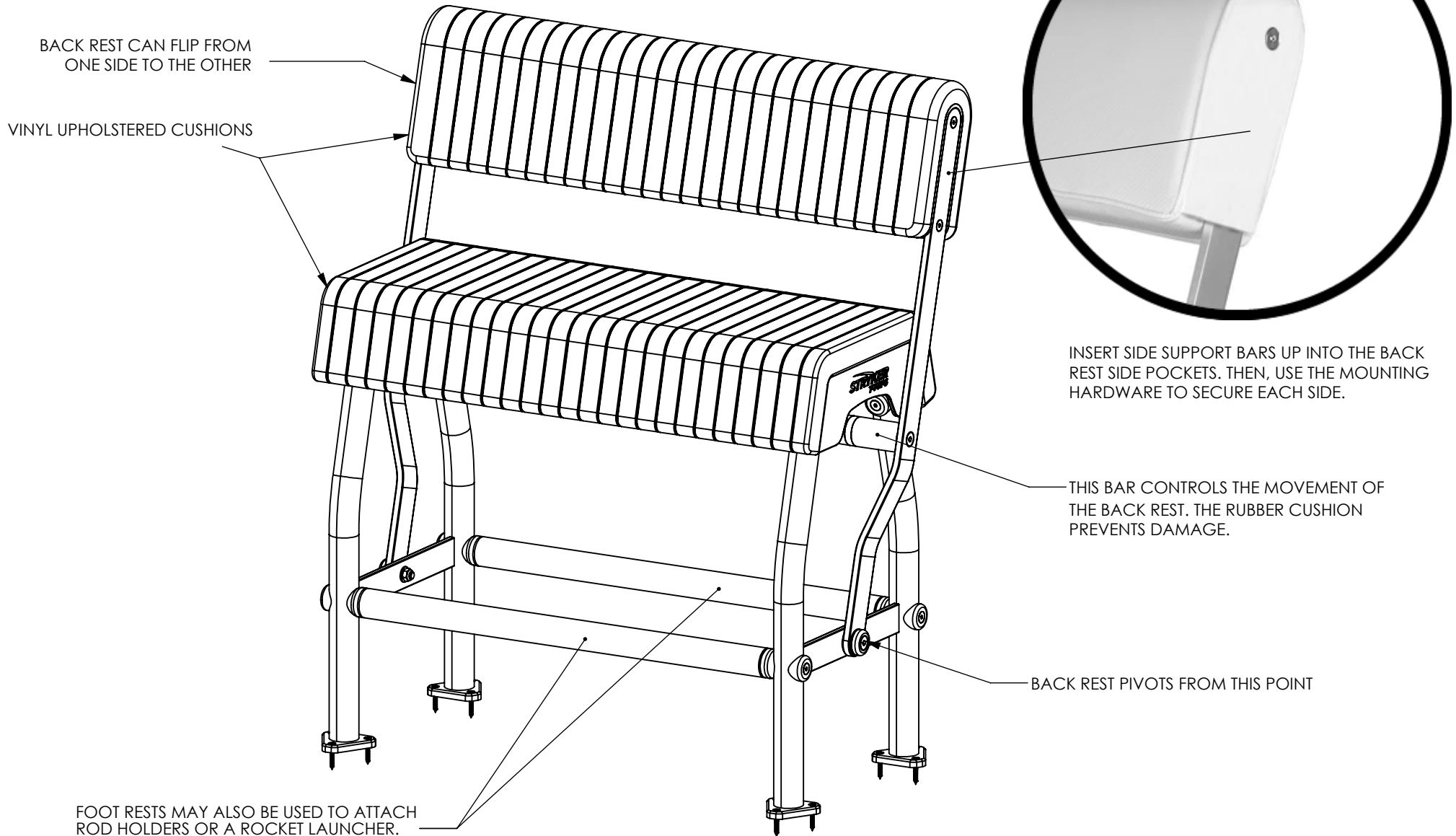

ITEM NO.	CODE	PROCESS	MATERIAL	FINISH	Seat Assembly/QTY.
1	LP_2_Seat_Assembly_150710-0	SEE SUB ASSEMBLY	SEE SUB ASSEMBLY	SEE SUB ASSEMBLY	1
2	SBHCSCREW 0.375-16x0.75-HX-S	STOCK ITEM	STAINLESS STEEL	STOCK	6
3	Leaning_Post_2_Leg_Assembly_150710-0	SEE SUB ASSEMBLY	SEE SUB ASSEMBLY	SEE SUB ASSEMBLY	2
4	SCHCSCREW 0.375-16x2.75x1.25-HX-S	STOCK ITEM	STAINLESS STEEL	STOCK	4
5	SCHCSCREW 0.375-16x3.25x1.25-HX-S	STOCK ITEM	STAINLESS STEEL	STOCK	4
6	Screw_Seat_240610-0	LATHE	6061 ALLOY	POLISH & ANODIZE	8
7	FLATCKT 0.25-14-type IA-AB-1.813-S	STOCK ITEM	STAINLESS STEEL	STOCK	12
8	Foot_Rest_Assembly_240610-0	SEE SUB ASSEMBLY	SEE SUB ASSEMBLY	SEE SUB ASSEMBLY	2

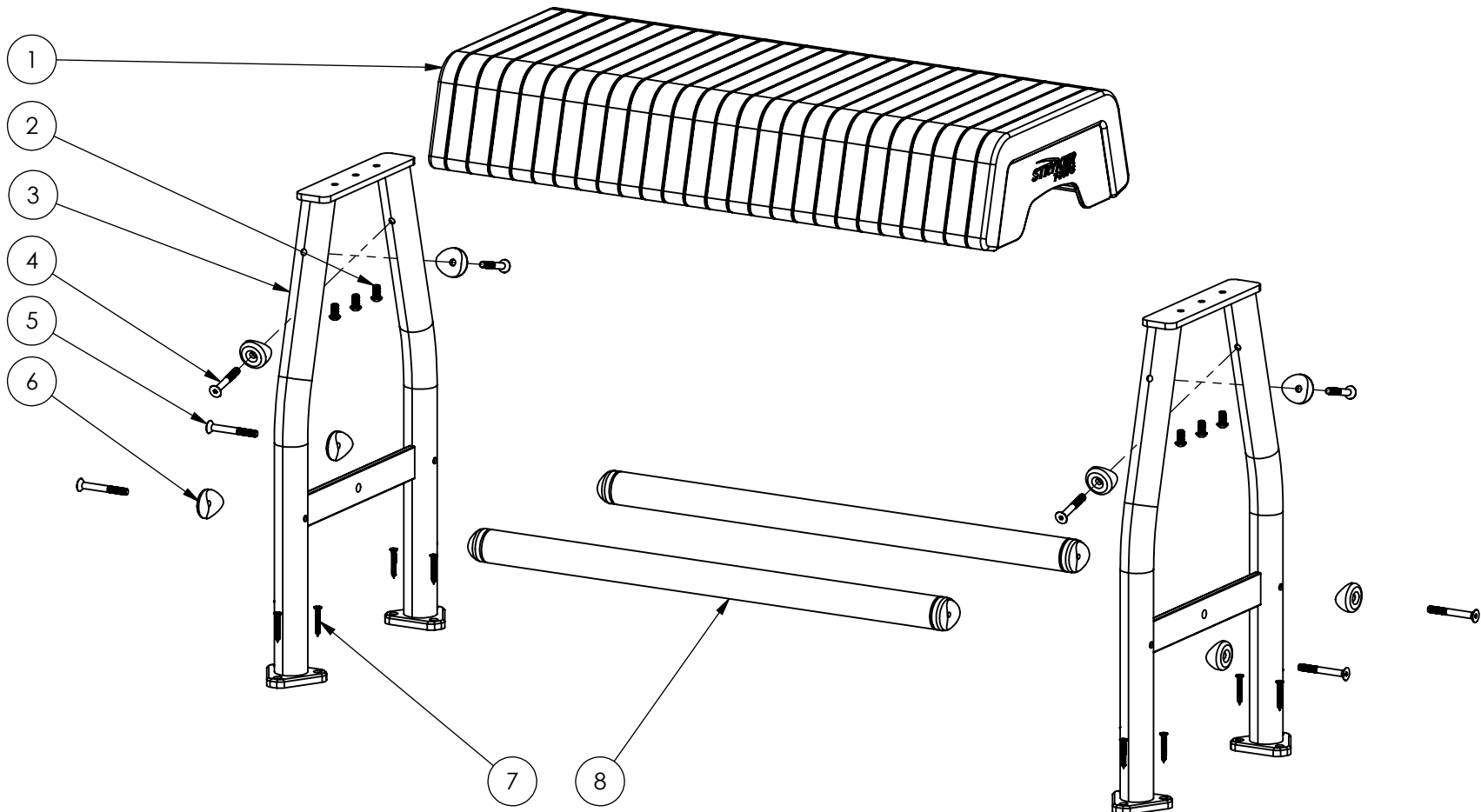

ITEM NO.	CODE	PROCESS	MATERIAL	FINISH	Back Rest Assembly/QTY.
1	Side_Support-160710-0	CUT TO LENGTH, BEND & DRILL	6061 ALLOY	POLISH & ANODIZE	2
2	SCHCSCREW 0.375-16x1.25x1.25-HX-S	STOCK ITEM	STAINLESS STEEL	STOCK	4
3	SCHCSCREW 0.5-13x1.5x1.5-HX-S	STOCK ITEM	STAINLESS STEEL	STOCK	2
4	SCHCSCREW 0.5-13x2.25x2.25-HX-S	STOCK ITEM	STAINLESS STEEL	STOCK	2
5	Pivot Seat 240610-0	LATHE	6061 ALLOY	POLISH & ANODIZE	2
6	Pivot Washer-160710-0	LATHE	NYLON (BLACK)	SMOOTH	4
7	Pivot_Bushing-160710-0	CUT TO LENGTH	NYLON (BLACK)	SMOOTH	2
8	Rubber Rest-160710-0	CUT TO LENGTH	FIRM RUBBER	SMOOTH	2
9	LP_2_Back_Rest_Bar_Assembly_190710-0	SEE SUB ASSEMBLY	SEE SUB ASSEMBLY	SEE SUB ASSEMBLY	1
10	LP_2_Back_Rest_Assembly_190710-0	SEE SUB ASSEMBLY	SEE SUB ASSEMBLY	SEE SUB ASSEMBLY	1
11	Preferred Narrow FW 0.5	STOCK ITEM	STAINLESS STEEL	STOCK	2
12	0.5 Inch Nylon Lock Nut	STOCK ITEM	STAINLESS STEEL	STOCK	2

